



RUSSELL COMPLETE FUEL SYSTEM KIT FOR CARBURETED VEHICLES

Catalog #641580 & #641583 for Edelbrock Thunder Series

AVS Carburetors

Catalog #641590 & #641593 for Holley or BG Demon Carburetors

INSTALLATION INSTRUCTIONS

Please study these instructions carefully before installing your new complete fuel system kit. If you have any questions, please call our **Technical Hotline at: 1-800-416-8628**, 7:00 am to 5:00 pm, Monday - Friday, Pacific Standard Time or e-mail us at **Edelbrock@Edelbrock.com**.

KIT CONTENTS

- | | |
|--|--|
| <input type="checkbox"/> 1 Edelbrock Fuel Pump #1791 | <input type="checkbox"/> 1 Russell -6 Tube Seal hose clamp with cover |
| <input type="checkbox"/> 1 Russell 8" 60-micron ProFilter with clamp | <input type="checkbox"/> 20 ft. Russell -6 hose |
| <input type="checkbox"/> 1 Edelbrock Electric Fuel Pump Relay Kit #1795 | <input type="checkbox"/> 10 Russell -6 cushion clamps |
| <input type="checkbox"/> 1 Russell Fuel Feed Line Kit (641580 / 641583 kits include 3" filter) | <input type="checkbox"/> 12 Cable ties |
| <input type="checkbox"/> 2 Russell Carburetor Adapter Fittings (641590 / 641593 kits only) | <input type="checkbox"/> 1 Edelbrock fuel pump block-off plate with gaskets & hardware for small-block Chevrolet |
| <input type="checkbox"/> 2 Russell adapter fittings for fuel pump (3/8" x -6 AN adapter) | <input type="checkbox"/> 1 Edelbrock fuel pump block-off plate with gaskets & hardware for big-block Chevrolet & Ford/Chrysler/AMC engines |
| <input type="checkbox"/> 3 Russell straight hose ends | <input type="checkbox"/> 10 ft. Russell 3/16" Wrap-It wire protective sleeve |
| <input type="checkbox"/> 1 Russell 90° hose ends | <input type="checkbox"/> 10 ft. Russell 5/16" Wrap-It wire protective sleeve |
| <input type="checkbox"/> 1 Russell 45° hose end | |

TOOLS & SUPPLIES RECOMMENDED

- | | |
|---|--|
| <input type="checkbox"/> Basic hand tools | <input type="checkbox"/> AN Wrenches |
| <input type="checkbox"/> Miscellaneous hardware for mounting components | <input type="checkbox"/> Pipe thread sealant |
| <input type="checkbox"/> Drill motor & bits | <input type="checkbox"/> Multimeter or test light |
| <input type="checkbox"/> Wire crimpers or soldering equipment | <input type="checkbox"/> Wire strippers |
| <input type="checkbox"/> Extra wire (Red & Black, 12 gauge & 18 gauge) | <input type="checkbox"/> Wire terminals & connectors |
| <input type="checkbox"/> 10A inline fuse | |

WARNING!!!

Gasoline and gasoline fumes are extremely flammable. Work in a well-ventilated area away from open flames, sparks, or other sources of ignition. Try to contain gasoline when connections are loosened, and clean up any spills immediately. Failure to do so can result in a fire or explosion.

IMPORTANT NOTE:

Proper installation is the responsibility of the installer. Improper installation will void warranty and may result in poor performance and engine or vehicle damage.

INSTALLATION PROCEDURE

1. DISCONNECT BATTERY ground(-) to prevent short that could damage electrical components or ignite gasoline or gasoline fumes. Stainless steel braid on hose included in #641580 and #641590 kit will conduct electricity.
2. Allow engine to cool. Relieve any residual fuel system pressure.
3. Remove all fuel system components and plumbing between fuel tank outlet and carburetor inlet, noting routing of hoses and lines. Cap off fuel tank outlet.
4. If needed, install appropriate supplied block-off plate onto fuel pump mounting boss on engine block using supplied gasket and hardware.

FUEL PUMP & 8-1/4" PROFILTER

5. Install supplied Russell adapter fittings into inlet and outlet of Edelbrock electric fuel pump, using pipe thread sealant (**See Fig. 1**).
6. Create mounting location for fuel pump and large Russell filter. Filter goes between tank and pump. Pump should be as close to fuel tank as possible, and as low as possible without being exposed to exhaust heat, suspension or driveline movement, or road hazards. Use fully-clamped pump mounting bracket as template for drilling mounting holes. **NOTE:** fabrication of an additional mounting bracket may be required (**See Fig. 1**).
7. Mount fuel pump in desired location. Mount filter with supplied clamp (**See Fig. 1**).

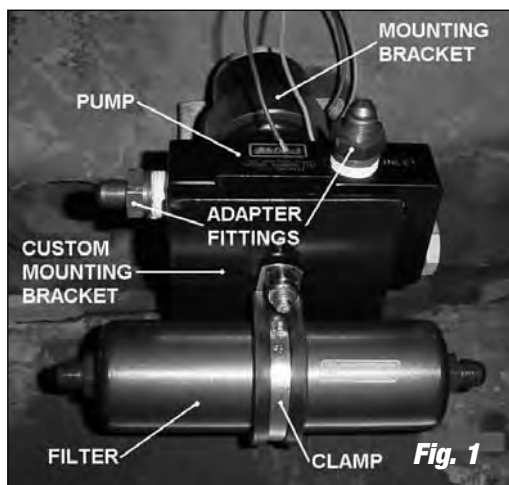

Fig. 1

CARBURETOR FEED LINE

641580/641583 Edelbrock Thunder Series AVS:

- 8a. Install supplied Russell carburetor fuel feed line using supplied banjo bolts and washers (**See Fig. 2**).
- 8b. Install small Edelbrock filter onto feed line inlet (**See Fig. 2**).

NOTE: An additional Russell adapter fitting or hose assembly may be required to relocate filter if application has inadequate clearance.

641590/641593 Holley/Demon:

9. Select appropriate carb bowl inlet adapters; lube threads and install using supplied shim sealing washers. Install lower flex hose assembly onto adapters (**See Fig. 3**).

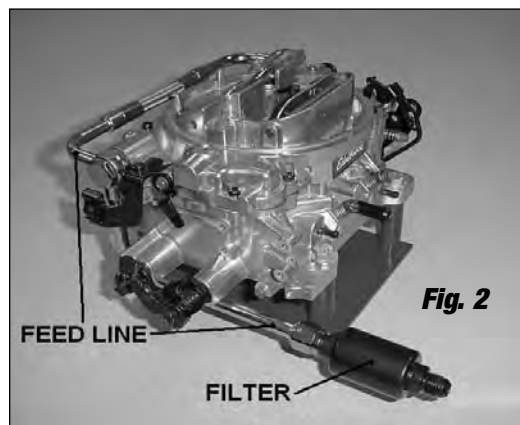

Fig. 2

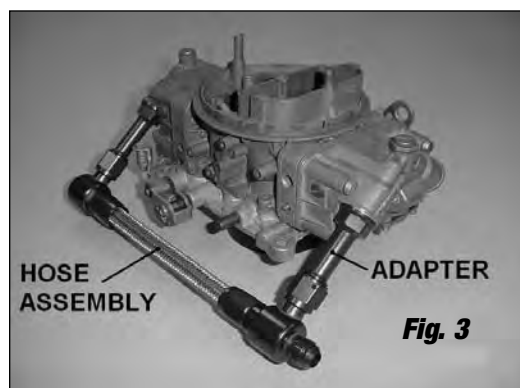
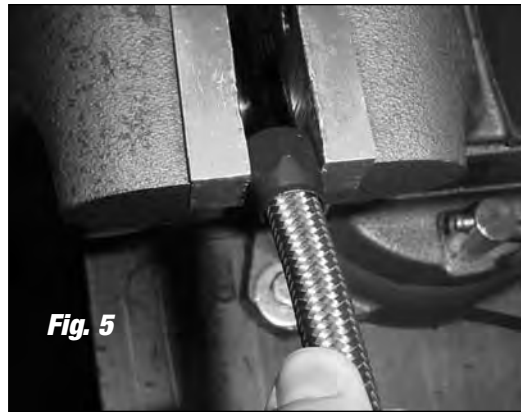
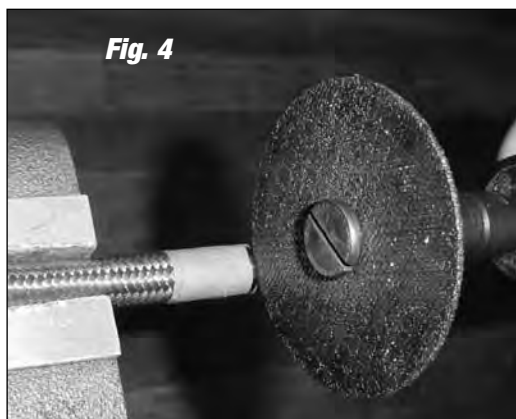

Fig. 3

HOSE ASSEMBLY

10. Select appropriate Russell hose ends for each section and temporarily screw them onto their respective adapter fittings to determine hose length. Use supplied Russell hose clamp with cosmetic socket cover to attach hose to barbed hard line coming off fuel tank. **NOTE:** Route hoses away from exhaust system and hazards such as driveshaft, exposed electrical connections (641580/641590 kit), and suspension pinch points. Do not expose hose to road hazards by routing below framerails. Also, some motorsports sanctioning bodies have regulations on fuel hose routing. Consult appropriate rulebook if vehicle will be used in competition.
11. Mark supplied Russell hose at point to cut and wrap hose over cut point with masking or strapping tape to minimize fraying. Allow enough slack in length for hose expansion, movement of components, and smooth bends. Hold hose in vise and cut with a pneumatic cutoff wheel, heavy-duty shears, or hacksaw. Cut hose as straight and square as possible (**See Fig. 4**). Remove tape after cutting hose.
12. Unscrew red socket from hose end and hold in vise. Push hose into socket, turning counter-clockwise, until hose is seated on step in socket (**See Fig. 5**). Make a mark on hose at end of socket.
13. Apply assembly lube (motor oil, etc.) to threads on hose end and in socket. Insert hose end nipple into socket/hose and start threads by hand (clockwise). Turn hose end with wrench until there is less than 1/16" between nipple hex and socket (**See Fig. 6**). Make sure socket did not move on hose by observing mark made in Step 16.
14. Repeat Steps 15, 16, & 17 for other end of hose.
15. Flush hose with solvent or hot soapy water and blow out with compressed air or let air dry (**See Fig. 7**). Install hose. Use supplied cushion clamps and/or cable ties to secure hose (**See Fig. 8**).



FUEL PUMP RELAY

16. Mount Edelbrock fuel pump relay at suitable location under hood (e.g. radiator support, inner fender, firewall) away from extreme heat (**See Fig. 9**).
17. Run one large (12 gauge) red relay wire back to red lead wire on fuel pump. Wire can be routed underneath along with other wires, hardlines, etc., or through interior. A 10A inline fuse is recommended on this circuit (not supplied). **NOTE:** Route wires so that any possible cutting, chafing, snagging, pinching, or burning from suspension, driveline, or exhaust components will be avoided. Cover wires with supplied Russell Wrap-It protective sleeve, and use supplied cable ties to secure wires.

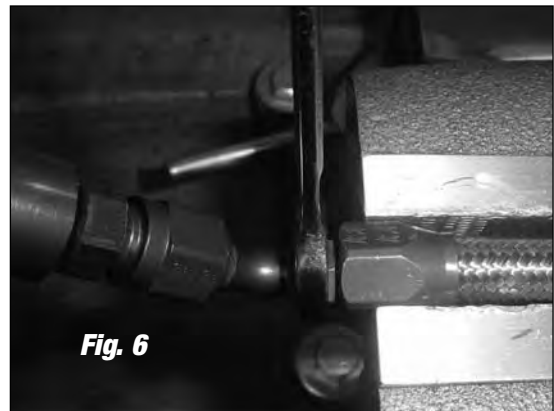

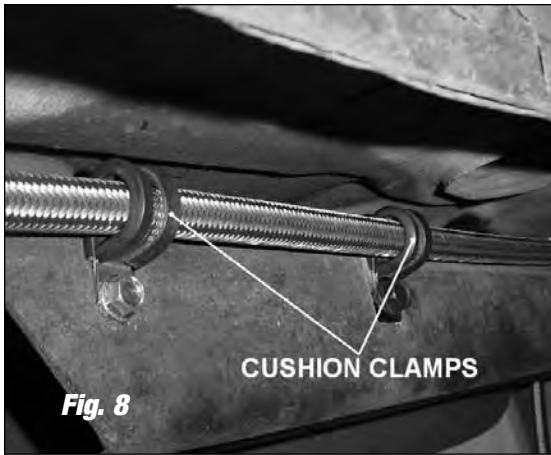

18. Connect other large (12 gauge) red relay wire to positive(+) battery terminal.
19. Connect small pink relay wire to 12V switched (key-on) power supply (e.g. terminal in fuse box or splice on ignition switch).
20. Connect black relay wire and black fuel pump lead wire to good chassis, engine, or battery ground.

SET-UP & OPERATION

21. Turn ignition on, but DO NOT START ENGINE. Check system thoroughly for leaks. Turn ignition off immediately if a leak is present and repair leak. Factory preset fuel system pressure for edelbrock fuel pump (1791) is 6.5 psi. The fuel system pressure can be externally adjusted from 5 psi to 10 psi. refer to Edelbrock fuel pump 1791 instructions for further details.
22. Start engine and evaluate system operation. Re-adjust fuel pressure if needed.
23. After a few driving cycles, re-check for and repair any leaks present. Check fuel system pressure and adjust the fuel pump, if necessary.

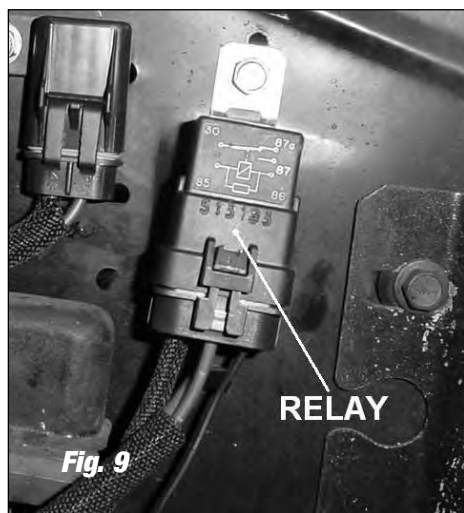

Edelbrock Corporation, 2700 California St., Torrance, CA 90503

Tech Line: 800-416-8628

E-Mail: Edelbrock@Edelbrock.com